

REV.	DESCRIPTION	DATE
A	JCH REVISED EXTENSIVELY	06-02-93
B	RBP CHANGE: ELECTRICAL ASSY. UPDATED, ECR #619	01-07-99
C	RBP CHANGE: 1) POT ROTATED 90°, ECR #1285	12-28-00

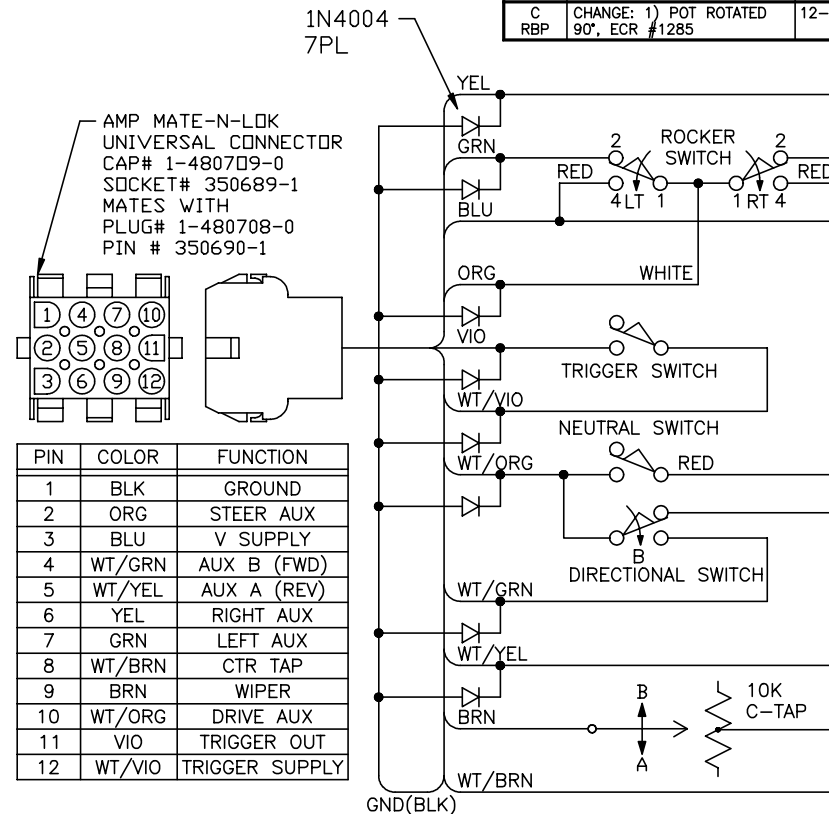

ELECTRICAL CONNECTION

- NOTES: 1) CONTROL HANDLE IS SPRUNG TO CENTER POSITION.  
 2) SLIDE LOCK IS SPRUNG TO LOCKED POSITION.  
 3) REPLACE #6-32 X 3/8 PAN HD PHIL & #6 INT TOOTH LOCKWASHER.

	<b>P-Q Controls, Inc.</b> 95 Dolphin Rd. Bristol, CT 06010 PHONE: (860) 583-6994 FAX: (860) 583-6011	DWG. NO. B-07667	REV. C
		SHEET 1 OF 1	SCALE 1:2
<b>M115-1274 INSTALLATION DWG</b> <b>REPLACEMENT: M115-747</b>			
DRAFTSMAN JCH	CHECK	PROJECT ENGINEER	DATE 04-30-93

**WARNING:** P-Q Controls, Inc. products are intended as general purpose switches. They are NOT safety devices and as with any general purpose devices, malfunctions may occur. If P-Q products are used to initiate an operation where false operation could be dangerous, POINT-OF-OPERATION GUARDING DEVICES must be installed and maintained to meet all appropriate OSHA and ANSI machine safety standards. P-Q Controls, Inc. shall not accept responsibility for installation, application or safety of systems.